

Forces in action

Question Paper 1

Level	A Level
Subject	Physics
Exam Board	OCR
Topic	Forces and Motion
Sub-Topic	Forces in action
Booklet	Question Paper 1

Time Allowed: 56 minutes

Score: / 46

Percentage: /100

Grade Boundaries:

A*	A	B	C	D	E	U
>85%	'77.5%	70%	62.5%	57.5%	45%	<45%

- 1 (a) Energy and work done are scalar quantities and have the same unit as each other.

State **two** other scalar quantities in physics that have the same unit as each other.

.....
 [1]

- (b) Two forces **A** and **B** act through the same point in an object. These two forces are shown in Fig. 2.1. No other forces act on the object.

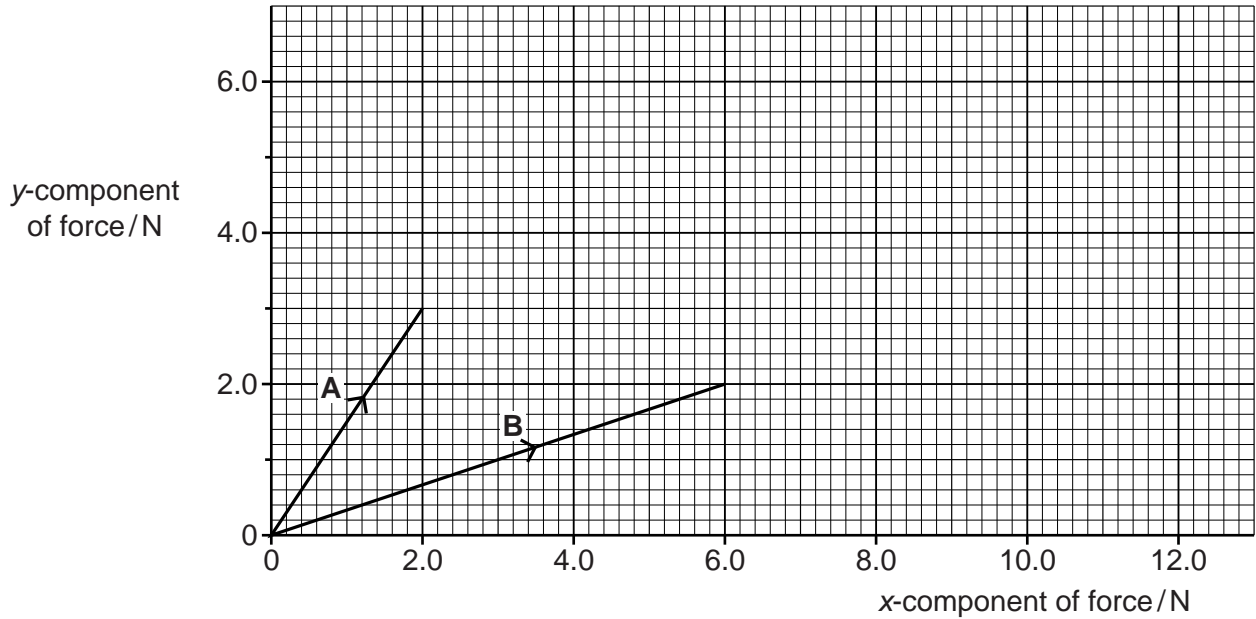

Fig. 2.1

- (i) Use Fig. 2.1 to determine the x- and y- components of the force **B**.

x-component = N

y-component = N

[1]

- (ii) Use Fig. 2.1 to determine the magnitude of the resultant of the two forces **A** and **B**.

resultant force = N [3]

(c) Fig. 2.2 shows a jet of water from the end of a hosepipe.

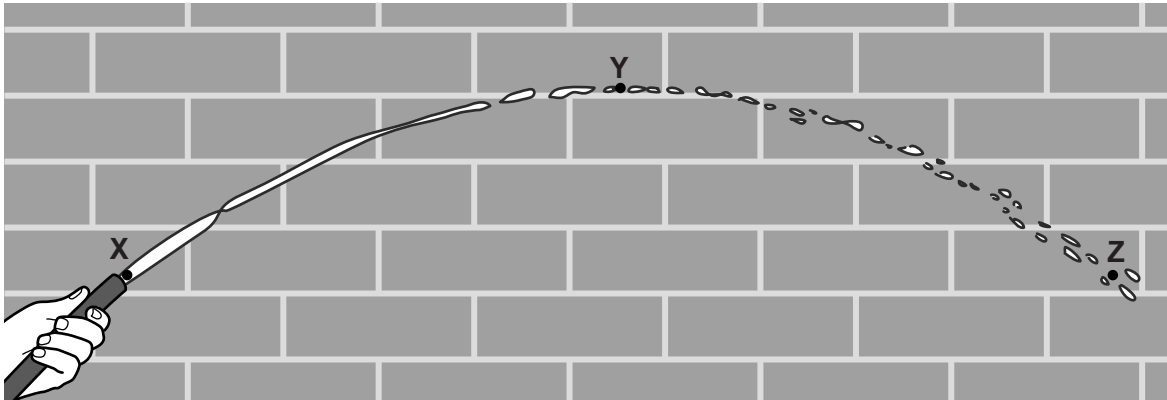

Fig. 2.2

Air resistance has negligible effect on the motion of the water jet. The water jet reaches maximum height at point Y.

(i) State the direction of the force acting on the water at Y.

..... [1]

(ii) Describe and explain how the horizontal component of the velocity of the water varies from point X to point Y.

.....
.....
.....
.....
..... [2]

(iii) Describe how the vertical component of the velocity of the water varies from point X to point Z.

.....
.....
.....
.....
..... [2]

- 2 (a) Fig. 3.1 shows the path taken by an aircraft as it flies from **A** to

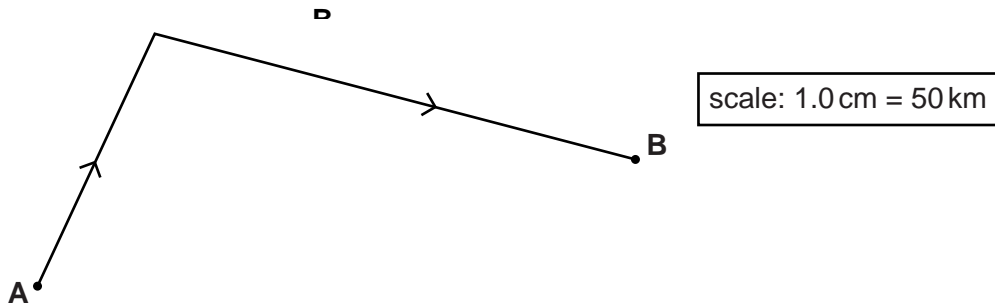

Fig. 3.1

On Fig. 3.1, a distance of 1.0 cm represents a distance of 50 km travelled by the aircraft. The aircraft takes 25 minutes to travel from **A** to **B**.

- (i) Use Fig. 3.1 to determine the magnitude of the average velocity of the aircraft as it travels from **A** to **B**.

average velocity = ms^{-1} [3]

- (ii) Without doing any calculations, explain why the average speed of the aircraft is not the same as the magnitude of its average velocity.

.....
.....
..... [1]

(b) Io is one of the many moons of Jupiter. It travels at constant speed around Jupiter in a circular orbit of radius 4.2×10^8 m. Io takes 1.5×10^5 s to orbit once around Jupiter.

(i) Calculate the speed of Io in its orbit.

speed = ms^{-1} [2]

(ii) Io has several active volcanoes on its surface. One of these volcanoes produces jets of sulphur with a velocity of 1.3 km s^{-1} that rise to 470 km above the volcano.

Calculate the constant acceleration of free fall on the surface of Io.

acceleration = ms^{-2} [3]

- 3 (a) The drag force F acting on a car travelling at a speed v is given by the

equation $F = kAv^2$

where A is the area of the front of the car.

Show that a suitable unit for the quantity k is kg m^{-3} .

[2]

- (b) A table tennis ball experiences drag as it travels through the air. Fig. 6.1 shows the ball in three different situations, **A**, **B** and **C**.

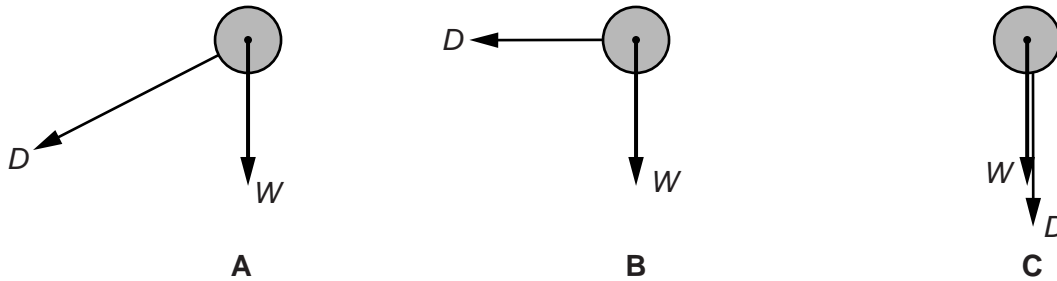

Fig. 6.1

The ball has weight W and the drag force is D .

- (i) On Fig. 6.1 draw an arrow to show the **direction** of travel of the ball in situation **A**. [1]

- (ii) In situation **B** the magnitude of the weight and the drag are the same.

Explain whether or not the ball is travelling at its terminal velocity.

.....

 [1]

(iii) Describe and explain the motion of the ball in situation C.

.....
.....
..... [2]

(c) Fig. 6.2 shows a DVD held above the ground.



Fig. 6.2

The DVD is dropped from rest. The circular face remains horizontal as it falls. The DVD does not reach terminal velocity before it hits the ground.

Describe and explain how the acceleration of the DVD varies from the instant it is dropped until just before it hits the ground.

.....
.....
.....
.....
.....
.....
.....
.....
..... [4]

- 4 (a) A block of concrete rests on the ground, as shown in Fig.

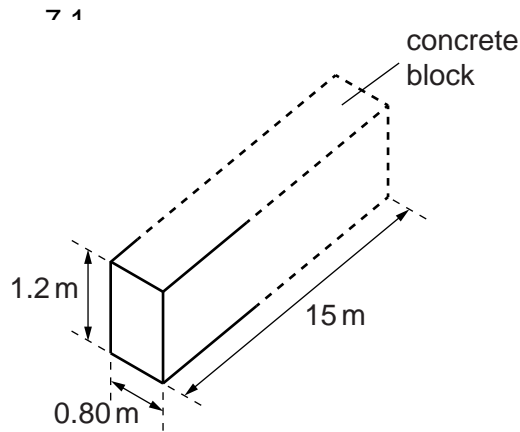

Fig. 7.1

The concrete block is 15 m long, 0.80 m wide and 1.2 m high. The density of concrete is $2.4 \times 10^3 \text{ kg m}^{-3}$. Calculate

- (i) the weight of the concrete

weight = N [2]

- (ii) the pressure exerted on the ground by the block of concrete.

pressure = Pa [2]

(b) Fig. 7.2 shows two vertical walls supporting a uniform horizontal platform in equilibrium.

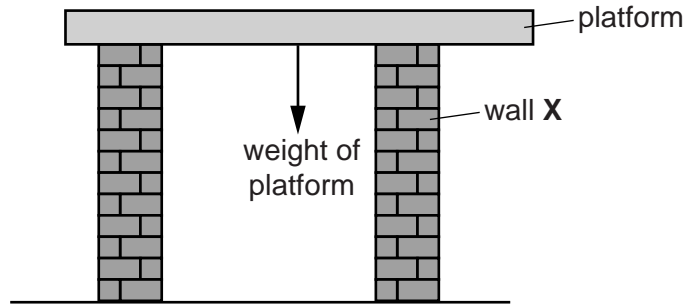

Fig. 7.2

(i) The net force acting on the platform is zero. State another condition that applies to this platform.

.....
..... [1]

(ii) The walls exert upward forces on the platform. An engineer suggests that the wall X should be moved a little further away from the centre of gravity of the platform and the opposite wall left where it is.

State and explain the effect this change would have on the force exerted by wall X on the platform.

.....
.....
.....
..... [2]

- 5 (a) Apollo-11 was the first manned spacecraft to land on the Moon. Fig. 1.1 shows part of the equipment left on the surface by the astronauts and the forces acting upon it.

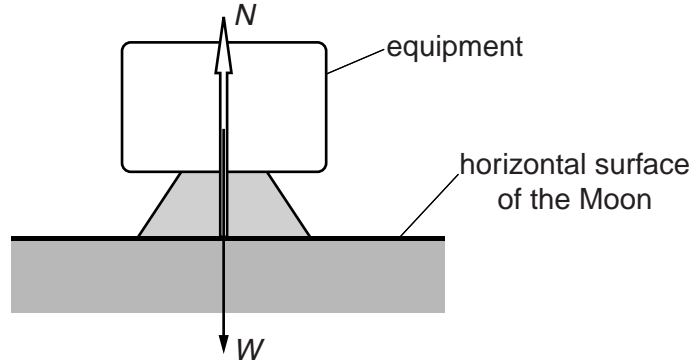

Fig. 1.1

According to Newton's third law interacting forces always occur in pairs. A student states that the normal contact force N is equal in magnitude to the weight W because of Newton's third law.

- (i) Give **two** reasons why the student's statement is incorrect.

.....
.....
.....
.....
.....
..... [2]

- (ii) Use Newton's third law to state the magnitude and location of the force pairing up with the weight W .

.....
..... [1]

- (b) While on the surface of the Moon one of the astronauts hit a golf ball with a club and declared that it went for 'miles and miles'. The ball was given an initial velocity u at a fixed angle θ to the horizontal. Show that the horizontal distance travelled by the ball is directly proportional to u^2 .

[3]

6 Fig. 2.1 shows an object held horizontally by a string.

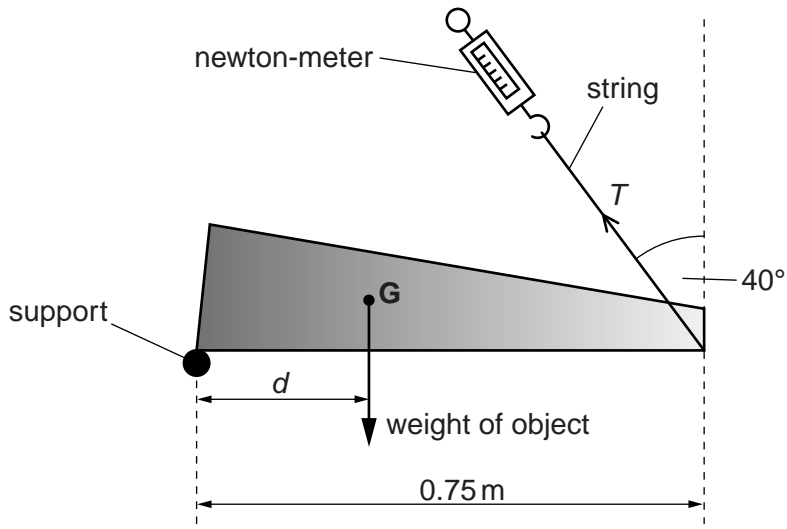

Fig. 2.1

One end of the object rests on a support and the other end is held by the string. The object is in equilibrium. Point **G** is the centre of gravity of the object. The mass of the object is 1.2 kg . The tension T in the string is 5.1 N . The string makes an angle of 40° with the vertical.

(a) Take moments about the support and calculate the distance d .

$d = \dots\dots\dots\text{ m}$ [3]

(b) Explain why the force at the support cannot be vertically upwards.

.....

[Total: 4]